

The SPW-220 optical-acoustic indoor siren is designed for application in burglary and panic alarm systems. The source of light are two LED sets, while the sound signal is generated by means of a piezoelectric transducer. The housing of the SPW-220 is made of PC LEXAN high-impact polycarbonate, thus it features a very high mechanical strength. Design of the siren ensures a high degree of tamper protection (against opening and/or pull-off from the mounting surface).

## 1. Description of Electronics Board

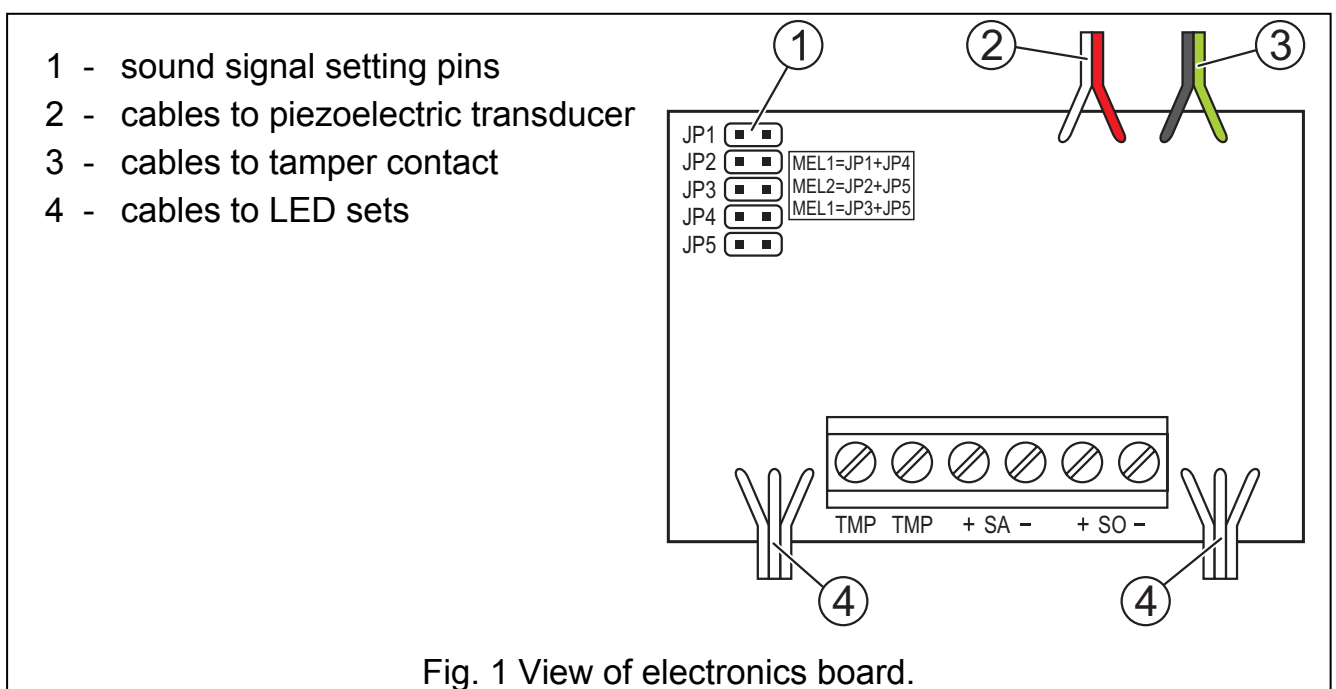

Connect the audible alarm control signal to the **+ SA -** terminals, and the visual alarm control signal - to the **+ SO -** terminals. The SPW-220 siren can interface with any alarm signal source where in the event of alarm condition 12V DC ( $\pm 15\%$ ) voltage appears on the alarm output.

Connect the **TMP** terminals to the tamper circuit of the alarm system. The tamper alarm is triggered after opening of the housing or pull-off of the device from the surface.

Set the jumpers on the **JP1 - JP5** pins to select one of the three sound signals for alarm signaling.

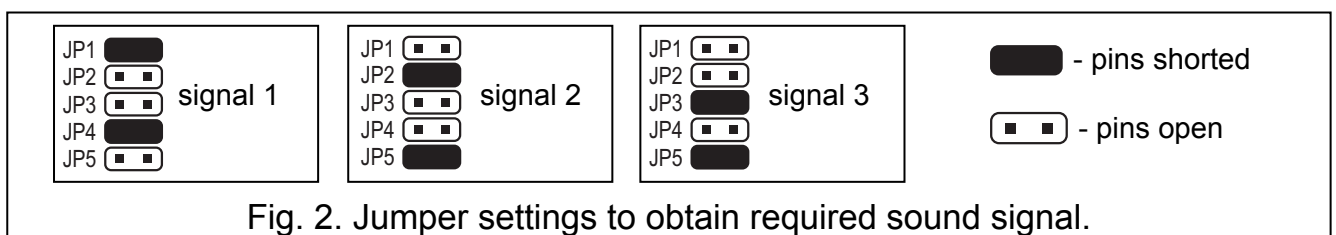

## 2. Installation

The SPW-220 indoor siren may only be used inside the protected facilities. It should be installed on a flat surface by means of screws and expansion bolts, at a place which is as hard to access as possible, so as to minimize the risk of tampering.

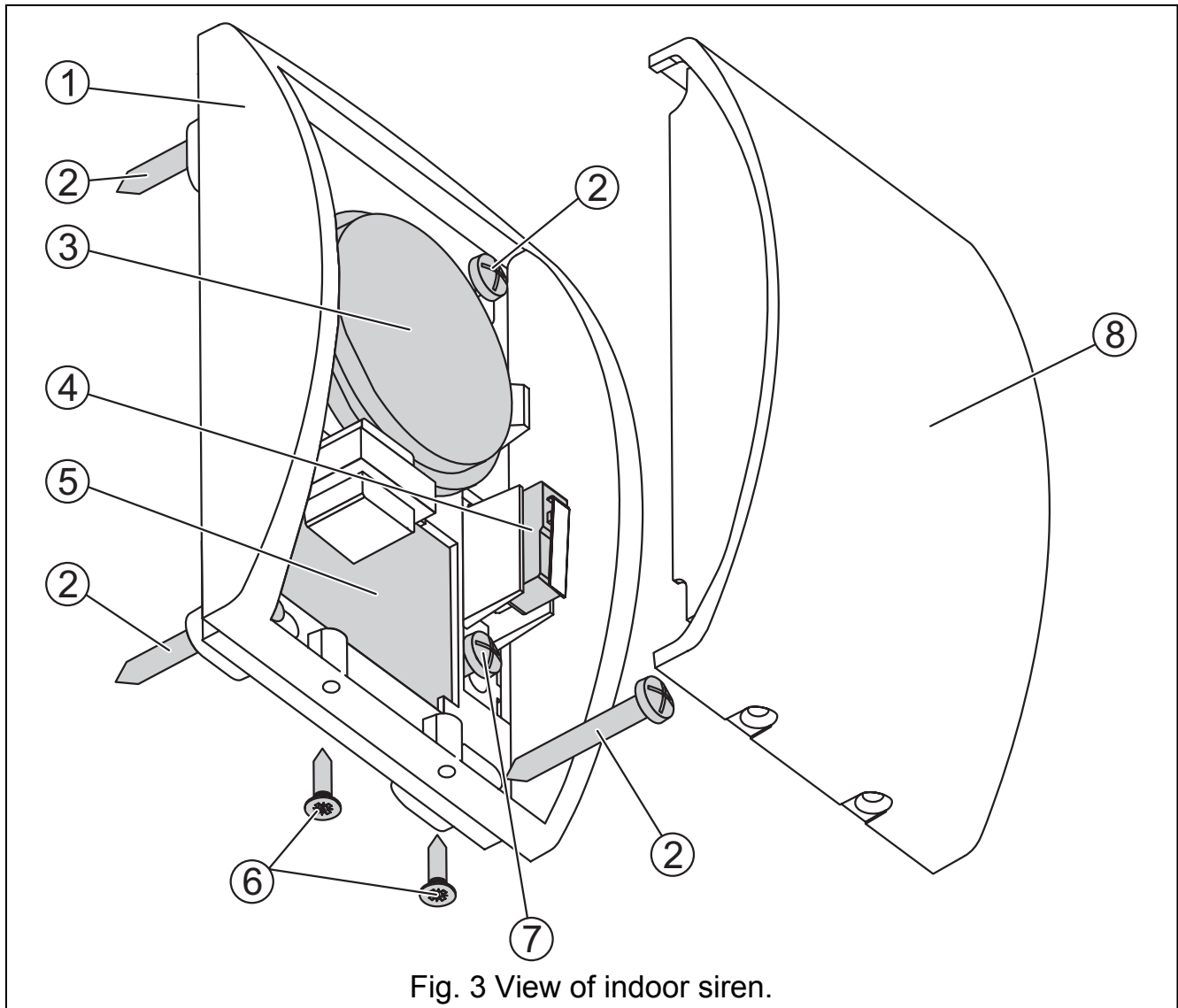
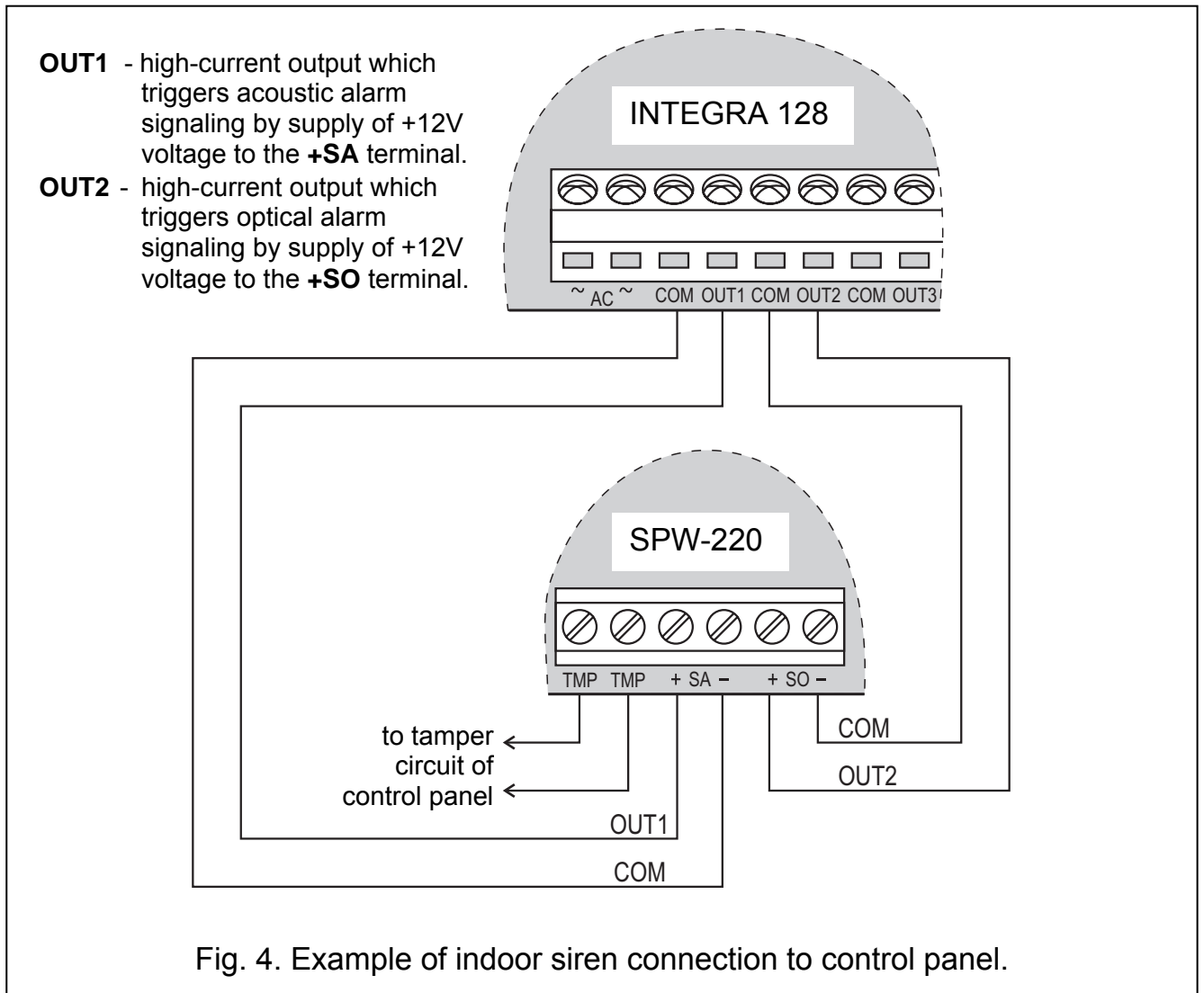

Fig. 3 View of indoor siren.

Explanations to Fig. 3:

- 1 – housing base
- 2 – screws securing the siren to mounting surface
- 3 – piezoelectric transducer
- 4 – tamper contact
- 5 – electronics board
- 6 – screws locking the housing cover
- 7 – screw fixing the housing tamper element to mounting surface
- 8 – housing cover



### 3. Technical Data

Nominal supply voltage .....	12V DC $\pm$ 15%
Average current consumption during operation:	
optical signaling .....	200mA
acoustic signaling.....	90mA
Working temperature range.....	-10°C...+55°C
Housing dimensions .....	87x134x37mm

<p>The latest EC declaration of conformity and certificates are available for downloading on our website <a href="http://www.satel.pl">www.satel.pl</a></p>	
---	---

SATEL sp. z o.o.  
ul. Schuberta 79  
80-172 Gdańsk  
POLAND  
tel. + 48 58 320 94 00  
[info@satel.pl](mailto:info@satel.pl)  
[www.satel.pl](http://www.satel.pl)

druk (4 na 1):  
4,1,4,1,2,3,2,3