

DG-1

DIGITAL GAS DETECTORS



dg1_en 05/09

The DG-1 microprocessor-based digital gas detectors are characterized by reliability and low current consumption. Due to a digital temperature compensation feature they can operate within a wide temperature range. Gas concentration above the threshold level triggers visual and audible alarm signals. The detectors are intended to be used as part of a security system.

The DG-1 series of digital gas detectors includes the following products:

DG-1 CO – carbon monoxide detector;

DG-1 LPG – propane-butane gas detector;

DG-1 ME – natural gas (methane) detector;

DG-1 TCM – soporific gas detector (e.g. chloroform vapors).

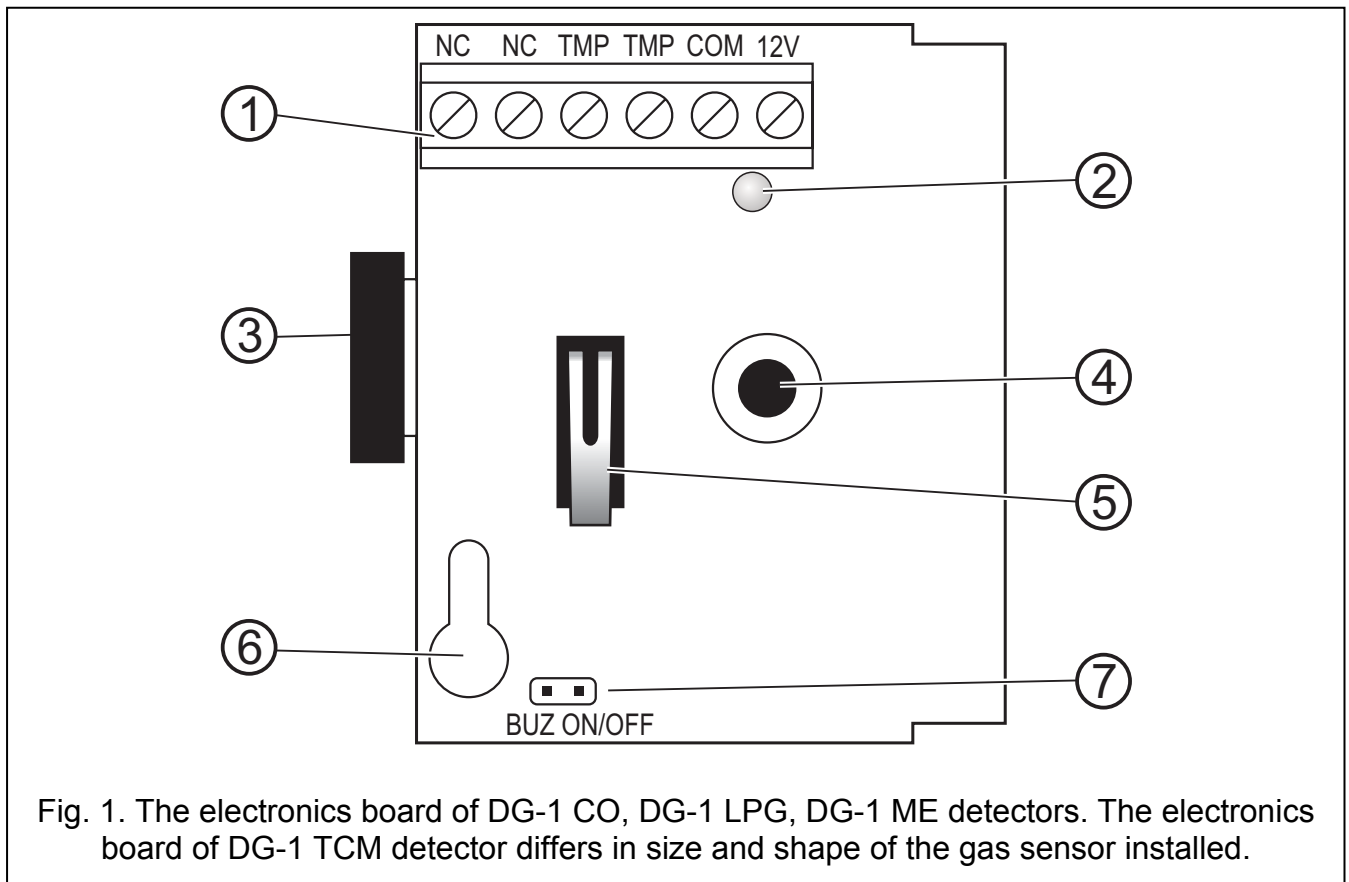

Fig. 1. The electronics board of DG-1 CO, DG-1 LPG, DG-1 ME detectors. The electronics board of DG-1 TCM detector differs in size and shape of the gas sensor installed.

Explanations to Fig. 1:

1 – terminals:

NC – alarm relay (NC)

TMP – tamper contact

- COM** – common ground
12V – power supply input
- 2 – LED indicator. Indicates by blinking activation, trouble and alarm of the detector. Depending on the detector type, the following LED colors are used:
- **red** – DG-1 CO (sensor type TGS2442)
 - **green** – DG-1 LPG (sensor type TGS2610)
 - **yellow** – DG-1 ME (sensor type TGS2611)
 - **blue** – DG-1 TCM (sensor type TGS832)
- 3 – buzzer. Indicates acoustically activation, trouble and alarm of the detector.
- 4 – gas sensor.
- 5 – tamper contact. Opening of the housing is signaled on TMP terminals.
- 6 – fixing screw hole.
- 7 – buzzer ON/OFF pins. Set the jumper to enable the audible signal, remove the jumper to disable it.

1. Alarm signaling

Depending on the detector type, the conditions of alarm signaling vary. They are described in Table 1. Additionally, the DG-1 LPG and DG-1 ME detectors feature the **prealarm function**.

	DG-1 CO	DG-1 LPG	DG-1 ME	DG-1 TCM
Gas concentration to trigger alarm	50 ppm for 75 minutes 100 ppm for 25 minutes 300 ppm for 1 minute	20% lower explosive limit		6000 ppm CHCl ₃
Gas concentration to trigger prealarm	-	10% lower explosive limit		-

Table 1. Conditions of alarm/prealarm signaling by the detectors.

Gas concentration reaching the dangerous level will trigger the alarm signal (visual and audible) and open the alarm relay. The alarm is signaled by long sounds and LED blinking, separated by long intervals (1 second LED blinking/sound, 1 second interval, etc.). The alarm signaling is on for the whole duration of dangerous gas concentration. Also the relay will remain open until the gas concentration drops below the alarm level. **The gas sensor reaction to a decrease in the dangerous gas concentration is delayed, hence the alarm signaling can stop even a few minutes after the gas concentration has dropped below the alarm level.**

The prealarm is signaled by short sounds and LED flashes, separated by long intervals (0.25 second LED blinking/sound, 1.75 second interval, etc.). The signaling continues as long as the methane/propane-butane concentration is above the 10% lower explosive limit, but just below the 20% lower explosive limit. The prealarm has no effect on the alarm relay status. The audible signaling can be disabled by removal of the BUZ jumper.

2. Autodiagnosics

The detector is monitoring the supply voltage (voltage drop below 9 V ($\pm 5\%$) will trigger a failure alarm) and testing performance of the gas sensor. Troubles are indicated by short sound signals and LED flashes separated by short intervals (0.25 second LED blinking/sound, 0.25 second interval, etc.). During a failure situation the alarm relay contacts will open.

3. Installation and commissioning



The DG-1 digital gas detectors are designed for indoor installation.

Considering specific character of the gases to be detected, the DG-1 TCM and DG-1 LPG detectors should be mounted in low position, just above the floor, the DG-1 ME detector in high position, just under the ceiling, and DG-1 CO detector at a height of about 1.5 meter.

1. Open the housing as shown in Fig. 2.

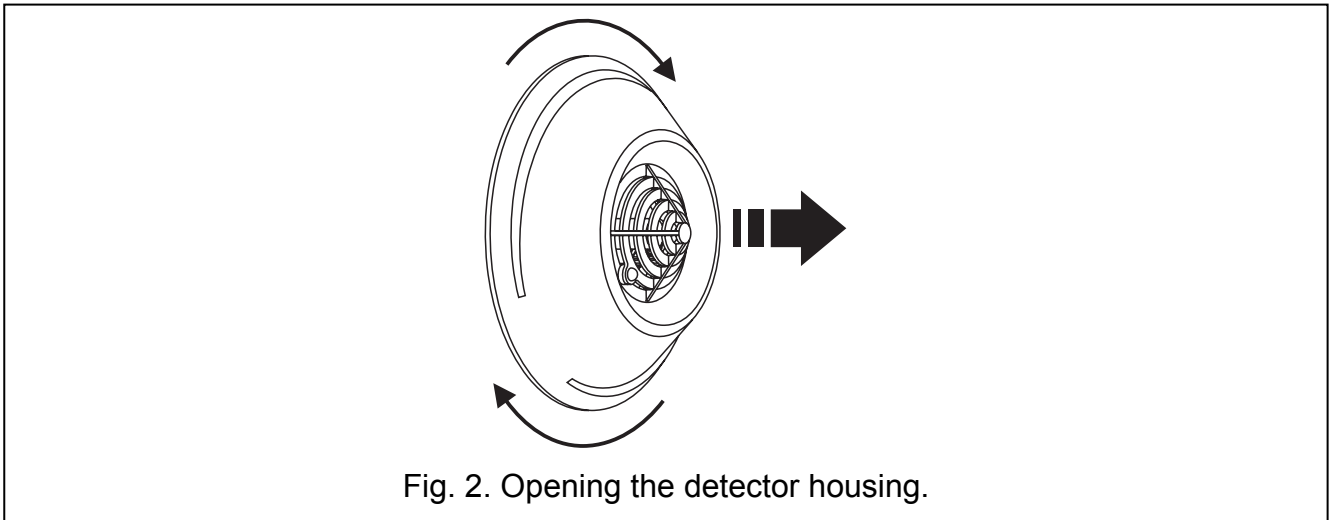

Fig. 2. Opening the detector housing.

2. Remove the electronics board.
3. Make suitable openings for screws and cable in the rear housing panel.
4. Pass the cable through the opening prepared.
5. Secure the rear housing panel to the wall.
6. Fasten the electronics board.
7. Connect the leads to corresponding terminals.
8. Using the jumper, decide whether the buzzer is to be enabled, or not.
9. Close the detector housing, making sure that the matchmarks on the cover and on the rear housing panel are aligned (see Fig. 3).
10. Switch on power supply of the security system. Putting the detector into operation is signaled by three short sounds, accompanied by blinking of the LED.

Notes:

- *It is not recommended to install the detector in spaces where industrial type equipment is working.*
- *During the detector operation the gas sensor heats up.*
- *The DG-1 detectors are tested during production process with special gas mixtures. It is not allowed to test the detector by any improvised methods (e.g. by using gas lighter gas). Wherever it is necessary to confirm functionality of the detector, use the testing kits offered by SATEL.*
- *The DG-1 TCM detector does not work selectively. Alarm may be triggered not only by chloroform vapors, but also by vapors of paints, lacquers, or alcohol, as well as by other organic compounds (e.g. refrigerants, like freon (chlorofluorocarbon), tetrafluoroethane, or chlorodifluoromethane, but also by cat urine).*
- *In the first five minutes after power-up, the DG-1 TCM detector is stabilizing and alarm may be triggered during that time.*

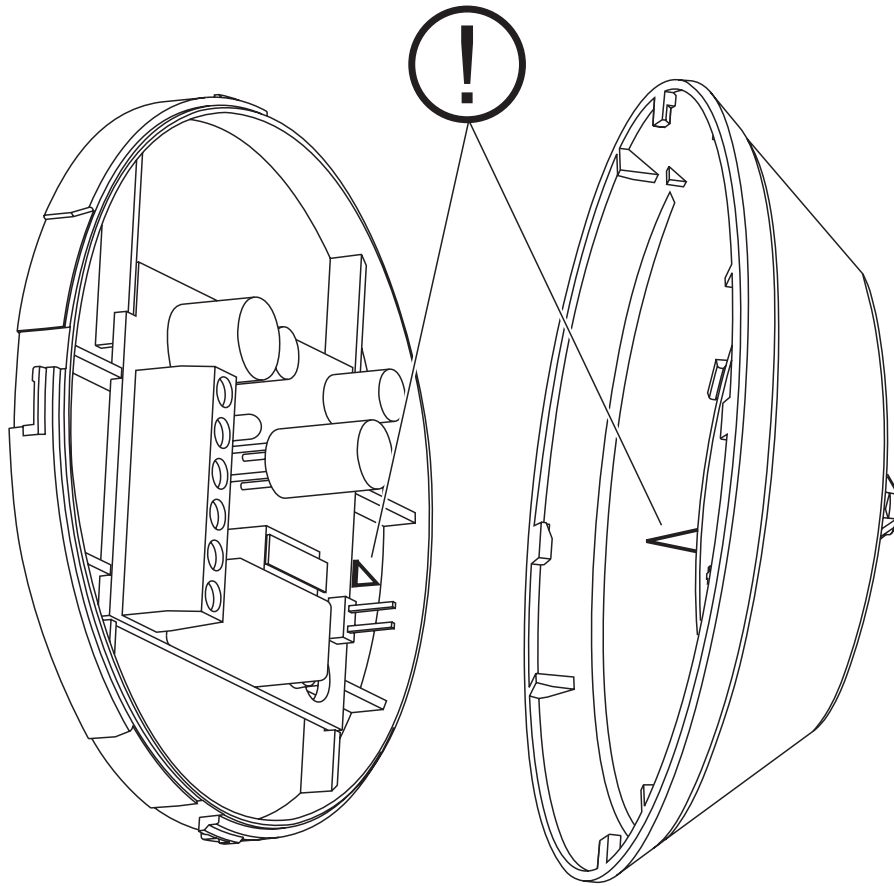

Fig. 3. Alignment of the matchmarks when closing the detector housing.

4. Technical data

Nominal supply voltage ($\pm 15\%$)	12 V DC
Current consumption, standby:	
DG-1 CO	9-20 mA
DG-1 LPG	30-50 mA
DG-1 ME	30-50 mA
DG-1 TCM	80-120 mA
Current consumption, maximum:	
DG-1 CO	20 mA
DG-1 LPG	50 mA
DG-1 ME	50 mA
DG-1 TCM	120 mA
Relay contacts rated load (resistive)	40 mA / 16 V DC
Operating temperature range	-10...+55 °C
Dimensions	\varnothing 97 x 36 mm
Weight:	
DG-1 CO	63 g
DG-1 LPG	62 g
DG-1 ME	63 g
DG-1 TCM	64 g

The average life time of DG-1 detector is 5 years.

SATEL sp. z o.o.
ul. Schuberta 79
80-172 Gdańsk
POLAND

tel. +48 58 320 94 00
info@satel.pl
www.satel.pl

The latest EC declaration of conformity
and product approval certificates are
available for downloading on website
www.satel.pl



druk (4 na 1):
4,1,4,1,2,3,2,3